



FERRARI TRIBUTE TO 1000 MIGLIA 2020
Brescia, from the 19th to 25th October 2020

SPECIAL RACE REGULATIONS

These Special Race Regulations were approved by the Italian Federation on 05/02/2020 with approval number RM/2/20. Within there are already reported and highlighted in yellow the variations reported in the Bulletin 01, 02 and 03 approved by ACI Sport respectively on 12/02/2020, 13/05/2020 and 28/07/2020.

ORGANISATION: 1000 Miglia Srl



PREVIOUS FERRARI TRIBUTE TO 1000 MIGLIA WINNER

Year	Drivers	Car	Cyl.	Cm³	CV	Brescia-Rome	Total time	Avg.
2010	Giardina - Di Serio	Ferrari Modena F1	8	3.586	400	2000	516	-
2011	Verghini - Fuso	Ferrari 512 TR	12	4.942	428	1992	490	-
2012	Verghini - Fuso	Ferrari 512 TR	12	4.942	428	1992	698	-
2013	Mingotti - Mingotti	Ferrari 458 Italia	8	4.499	570	2011	707	-
2014	Garelli - Garelli	Ferrari 458 Speciale	8	4.499	605	2014	1772	14666
2015	Garelli - Garelli	Ferrari 458 Speciale	8	4.499	605	2014	1234	18682
2016	Garelli - Garelli	Ferrari F12 TDF	12	6.262	570	2016	1061	19128
2017	Garelli - Garelli	Ferrari F12 TDF	12	6.262	570	2016	1165	24315
2018	Bianchi - Mozzi	Ferrari California	8	4.296	460	2010	605	33164
2019	Mozzi – Biacca	Ferrari 458 Spider	8	4.499	605	2012	868	34106



INDEX

Articles:

	Interpretation	page 28
1.	Organisation	page 28
2.	Race officials	pages 28-29
	Programme	pages 30-31
3.	Race	page 32
4.	Route	page 32
5.	Competitors, drivers and cars allowed	pages 32-35
6.	Race numbers starting order	page 35
7.	Entries	pages 35-39
8.	General obligations	pages 39-41
9.	Running of the Race	pages 41-43
10.	Maximum lateness	pages 43
11.	Penalties and disciplinary measures	pages 44
12.	Classifications, complaints, appeals	page 45
13.	Prizes	pages 45
14.	General rules	pages 46
15.	Insurance	page 46-47

Attachments:

1.	Facsimile Medical Certificate for non-competitive sports activity	page 49
2.	Facsimile Medical Certificate for competitive sports activity	page 50
3.	Positioning of Race numbers on cars	page 51
4.	Times and Distance Table <i>(the TDT will be distributed together with the Road book)</i>	[omissis]
5.	Map of the route <i>(The map of the Race route may be subject to modification and will be distributed together with the Road book)</i>	page 52
6.	Control signs	page 53-54
7.	Table of scores for Time Trials (PC/TT)	pages 55-56
8.	Table of scores for Average Trials (PM/AT)	pages 57-58



INTERPRETATION

All the times states in these SR are understood as referring to the Time Zone in use in Italy, namely "Greenwich Mean Time + 1 hour" conventionally UTC (GPS) signal | Italy: GMT+1

The acronym "ASN" stands for Autorità Sportiva Nazionale (National Sport Authority).

Value Added Tax (VAT) will be applied on all amounts stated in these SR at a rate of 22% (updated to 24th January 2020). Any variation on this percentage will be notified in the Bulletin and will be enforced in compliance with the laws issued by Italy.

To all legal effects, the Italian version of these general Regulation will take precedence. The English translation of the same is understood as being solely for information purposes.

Article 1 - ORGANISATION

These Supplementary Regulations (SR) are drawn up in conformity with the International Sport Code (and relevant attachments, where applicable), with the National Sport Regulations (and relevant attachments where applicable) and with other provisions of the ACI Sport, which are understood to regulate whatever is not indicated in the following articles.

The Organiser states that the race will have all the necessary administrative authorisations and the required insurance coverage.

1.1 - OPERATIONS COMMITTEE

Chairman:	Mr. t.b.a.	
Vice Chairman:	Mr. t.b.a.	
Members:	Mr. t.b.a.	
	Mr. t.b.a.	
	Mr. t.b.a.	
	Mr. t.b.a.	
	Mr. t.b.a.	
	Mr. t.b.a.	
Secretary:	Mr. t.b.a.	
Head office:	1000 MIGLIA s.r.l. - Via Enzo Ferrari, 4/6 - 25134 Brescia	

Article 2 – RACE OFFICIALS

Chairman of Stewards	Mr. t.b.a. (ASN Sport Delegate)	licence
- Steward	Mr. t.b.a.	licence
- Steward	Mr. t.b.a.	licence
Stewards secretary	Mr. t.b.a.	licence
Clerk of the course:	Mr. Lucio DE MORI	licence 20623
Deputy Clerk of the course:	Mr. t.b.a.	licence
Event Secretary:	Mr. t.b.a.	licence
Safety Manager - Route Delegate:	Mr. t.b.a.	licence
Doctor:	Dr. t.b.a.	licence
Competitor Relations Officers:	Mr. t.b.a.	licence
	Mr. t.b.a.	licence
	Mr. t.b.a.	licence
	Mr. t.b.a.	licence
	Mr. t.b.a.	licence
Merit Offices:	<u>The list will be published by a Bulletin</u>	
Sports Inspectors:	<u>The list will be published by a Bulletin</u>	
Scrutineers and Scrutineer Assistant:		

Ferrari Tribute to 1000 Miglia 2020
Regolamento Particolare di Gara – Special Race Regulations



	Mr. t.b.a. (ACI Sport delegate)	licence
	<u>The list of will be published by a Bulletin</u>	
Judges of Fact:	<u>The list of will be published by a Bulletin</u>	
Route Marshals:	of the Automobile Club Brescia and of the Automobile Clubs of other affected Provinces	
Time keeping Service: t.b.a.	
Head of Timing Service:	Mr. t.b.a.	licence
Rankings Compiler:	The Clerk of the course	
Press Officer:	Mr. t.b.a.	



PROGRAMME

Programme before the race week

Monday 3 February 2020

Date of publication of Special Race Regulations	Website
Opening date for entries	Race Secretary

Friday 20 March 2020 at 16:00

Closing Date for entries	Race Secretary
--------------------------	----------------

by Friday 27 March 2020

Communication to entrants of their acceptance, acceptance of the cars And relative coefficients assigned	Race Secretary
Publication of list of Competitors and cars accepted	Website

Thursday 30 April 2020

Deadline for the refund of deposit payment from competitors who have not been accepted and who were not on the waiting list	Race Secretary
--	----------------

Friday 18 September 2020 at 23:59

Final date for communicating or for the free of charge variation of the data of the drivers not indicated during the entry phase or subsequently changed (the onerous replacements requested from September 18 th will not be reported on the organizer's publications)	Race Secretary
Deadline for the free of charge request of change an entered car	Race Secretary

Thursday 1 October

Closing Date for the waiting list	Race Secretary
-----------------------------------	----------------

from Monday 12 October 2020

Briefing of the Organisers and the Clerk of the Course (<i>briefing recorded</i>)	Sent to each entrant
---	----------------------

Tuesday 13 October 2020

Publication of individual inspections	Website – ONB
---------------------------------------	---------------

Sunday 18 October 2020 at 12:00

Publication of individual starting order and times of the 4 Legs	Website – ONB
--	---------------

Programme for the Race Week

The times shown on the programme for all activities which precede the start of the race will be confirmed by a boards showing the official time of the event, placed in the inspection area by the Timekeeping service.

All crew members who have not reported within the times stated in this SRR will be understood as having withdrawn and will not be admitted to the race; no exceptions will be made.

Monday 19 October 2020

10:00 - 17:00 Pre race sports and technical checks and Distribution of Road book (according to individual convocation times communicated) Briefing of the Organiser and Clerk of the Course (recorded)	Brescia, Paddock Expo
--	-----------------------

Tuesday 20 October 2020

10:00 - 17:00 Pre race sports and technical checks and Distribution of Road book (according to individual convocation times communicated) Briefing of the Organiser and Clerk of the Course (recorded)	Brescia, Paddock Expo
--	-----------------------

Wednesday 21 October 2020

10:00 - 17:00 Pre race sports and technical checks and Distribution of Road book	Brescia, Paddock Expo
--	-----------------------

Ferrari Tribute to 1000 Miglia 2020
Regolamento Particolare di Gara – Special Race Regulations



(according to individual convocation times communicated)
 Briefing of the Organiser and Clerk of the Course (recorded)

Thursday 22 October 2020

07:30 - 08:30	Pre race sports and technical checks and Distribution of Road book <i>(according to individual convocation times communicated)</i> Briefing of the Organiser and Clerk of the Course (recorded)	Brescia, Paddock Expo
11:30	Briefing dell'Organizzatore e del Direttore di gara	Desenzano d/G, Via Porto Vecchio, 34
12:30	Publication of list of competitors and accepted cars	Website-Official Notice Board
from 13:40	Lining up for start of Leg 1	Desenzano d/G – L.go Battisti
14:10	Departure of first car – Leg 1	Desenzano d/G – L.go Battisti
20:45	Arrival of first car – Leg 1	Cervia, Milano Marittima

Friday 23 October 2020

05:10	Publication of partial ranking of Leg 1	Website-Official Notice Board
from 05:10	Lining up for start of Leg 2 <i>(minimum 30' before the individual start time)</i>	Cervia, Milano Marittima
05:40	Departure of first car – Leg 2	Cervia, Milano Marittima
20:00	Arrival of first car – Leg 2	Roma-Villa Borghese

Saturday 24 October 2020

05:10	Publication of partial ranking of Leg 2	Website-Official Notice Board
from 05:10	Lining up for start of Leg 3 <i>(minimum 30' before the individual start time)</i>	Roma,t.b.a.....
05:40	Departure of first car - Leg 3	Roma,t.b.a.....
20:10	Arrival of first car - Leg 3	Salsomaggiore Terme

Sunday 25 October 2020

06:00	Publication of partial ranking of Leg 3	Website-Official Notice Board
from 06:00	Lining up for start of Leg 4 <i>(minimum 30' before the individual start time)</i>	Salsomaggiore Terme
06:30	Departure of first car - Leg 4	Salsomaggiore Terme
15:10	Arrival of first car - Leg 4 and	Brescia, Iveco Park
15:30	Passage on the ramp	Brescia, Viale Venezia
16:30	Publication of final ranking	Website - Race Notice Board
16:30	Prize giving ceremony	Brescia, Piazza Loggia

Race Headquarters, Race Secretary and Paddock

Brixia Expo - Fiera di Brescia, Via Caprera 5 - 25125 Brescia

Leg Secretaries

Cervia - Cervia Turismo Srl - Torre San Michele - Via Evangelisti, 4
 from 20:00 of **Thursday 22** to 01:00 of **Friday 23 October 2020**

Rome - Rome Marriott Park Hotel, Via Vittorio Veneto 70 - Hall
 from 18:00 to 24:00 of **Friday 23 October 2020**

Salsomaggiore Terme – Grand Hotel Salsomaggiore
 from 18:00 of **Saturday 24** to 01:00 of **Sunday 25 October 2020**

Official Notice Board (ONB)

Brescia (competition Headquarters), Leg Secretaries (only daily communication) and Website



Website www.ferraritribute.1000miglia.it

Synchronization of the Organisation's time-keeping systems: **UTC (GPS) signal** | Italia: GMT+1

Article 3 - RACE

The Organiser 1000 MIGLIA s.r.l. based in Brescia - Via Enzo Ferrari 4/6 - Brescia, holder of the licence n. 356540, currently valid, announce and organise, as from **from Monday 19 to Sunday 25 October** 2020 a Classic Regularity Race for Modern Cars, Grand Event, to be known as:

FERRARI TRIBUTE TO 1000 MIGLIA 2020

Article 4 - ROUTE

The race route will have an overall length of Km **1.746,35** and will be described in the Itinerary Table (TDT) attached to these SR, and of which it is an integral part, and in the Road Book. The TDT will also show the methods of carrying out the timed stages for ranking.

There will be **17** Time Controls (CO/TC), **107** Time Trials (PC/TT), **7** Average Trials (PM/AT) with a total of **20** readings and **22** Passage Controls (CT/PC).

The start and finish of the race are scheduled at the places and times indicated in the Race Programme.

The race will take place on roads open to traffic, barring any limitations set by the competent Administration Authorities, with average speeds not exceeding 50 Km/h.

Any route changes due to road works, or temporary obstructions, will be notified with Bulletins directly on site, if possible, by the Police or by persons appointed by the organisation.

Article 5 - COMPETITORS, DRIVERS AND CARS ALLOWED

5.1 ACCEPTED COMPETITORS AND DRIVERS

5.1.1 Competitors, and crew members must hold a valid ACI Sport Competitor/Driver's Licence or a valid regularity licence (for Italian competitors/Drivers) or a valid international Competitor/Driver's licence, issued by their ASN (for foreign competitors/drivers).

All crew members must hold a valid Driver's licence during all phases of the race. Foreign drivers must also have an international Driver's licence.

5.1.2 To the members of foreign crews who do not hold a valid International Competitor/Driver licence, issued by their ASN, ACI Sport regularity licence may be issued at pre-race checks valid only for the Ferrari Tribute to 1000 Miglia 2020, after payment of the relative fees.

5.1.3 For each vehicle, a competitor may register a crew comprising of maximum 2 persons, who must be on board the vehicle during all phases of the race.

5.1.4 A competitor who is a physical entity, registering a vehicle for the race must always be on board the vehicle throughout the race.

5.1.5 During all the phases of the race the vehicle may be driven only by crew members who have been verified and accepted with that specific vehicle.

5.1.6 Crew members below the age of 18 and older than 79 years of age will not be accepted.

5.1.7 Passengers will not be allowed, that is, crew members who have not been verified and who are not in possession of the requirements of Article 5.1.1 and 5.1.6 of these SRR.

5.1.8 The substitution of a competitor after the close of registration, is not permitted.
Crew members may be substituted:



- with the authorisation of the Organiser, up to the start of pre-race checks;
- with the authorisation of the Stewards, from the start of checks until publication of list of admitted competitors and crews and of the accepted competition cars.

The substitution of two members of the crew is subject to the approval of the Organiser, in accordance with the ASN of the organiser.

Up to 23:59 on **September 18th 2020** the first substitution of **a both crew members** or the inclusion of **a names** not previously notified, are free of charge. **From Saturday September 19th 2020** all subsequent replacement **or insertion** of a crew member will be charged and amount of € 366,00 (equal to € 300,00 + VAT) as administration fees. If payment is not made, the request for substitution will not be considered valid.

Any request received after Thursday September 18th 2020 will not guarantee the visibility of the names in the official race publications.

5.1.9 DOCUMENTATION REQUIRED IN ORDER TO OBTAIN A SPORTS LICENCE DURING PRE RACE CHECKS

The maximum age for obtaining the regularity licence, whether daily for foreigners or annual for Italians, is 75 years for both sexes. The possibility of raising the maximum age of competitive activity up to 79 years is allowed. Below is the list of the documentation necessary for obtaining the prescribed licence:

a) Drivers of Italian nationality UNDER 75 at the date of the closure of administrative verification

In order to issue/renew the licence, the following documents are required:

- medical certificate for non-competitive sports activities (Facsimile in Attachment 1 to these SR) obtained in Italy as per current regulations;
- driving licence (for both crew members);
- ACI membership card (for those not in good standing with the association, it will be possible to renew/issue this on-site by communicating the data of the car used every day, or the licence plate number of the historic car entered in the competition, depending on the type of ACI Service required).

b) Drivers of Italian nationality OVER 75 at the date of the closure of administrative verification

In order to issue/renew the licence, the following documents are required:

- medical certificate for competitive sports activities (Facsimile in Attachment 2 to these SR) obtained in Italy as per current regulations;
- driving licence (for both crew members);
- ACI membership card (for those not in good standing with the association, it will be possible to renew/issue this on-site by communicating the data of the car used every day, or the licence plate number of the historic car entered in the competition, depending on the type of ACI Service required).

c) Drivers not of Italian nationality UNDER 75 at the date of the closure of administrative verification

In order to issue/renew the licence, the following documents are required:

- medical certificate for non-competitive sports activities (Facsimile in Attachment 1 to these SR) obtained in Italy as per current regulations; alternatively, a medical certificate of good health issued abroad, written in English, signed and stamped by a doctor;
- self-certification stating you do not hold other valid licences issued by other ASN and to not having incurred disciplinary sanctions;
- national and international driving licence (both crew members).

d) Drivers not of Italian nationality OVER 75 at the date of the closure of administrative verification

In order to issue/renew the licence, the following documents are required:

- medical certificate for competitive sports activities (Facsimile in Attachment 2 to these SR) obtained in Italy as per current regulations; alternatively, a medical certificate of good health issued abroad, written in English, signed and stamped by a doctor.
- self-certification to not possessing other valid licences issued by other ASN and to not having incurred disciplinary sanctions;
- national and international driving licence (both crew members).



5.2 ACCEPTED CARS

5.2.1 Up to 100 vehicles, exclusively of the FERRARI make, will be accepted. Of these, a maximum of 35, defined as "historic" (manufactured from 1958 to 1990), will be allowed. The remaining cars, defined as "modern", manufactured from 1991 to now, will be accepted only if they belong to the following models or have the following types of engine:

1. models: GTO, F40, F50, Enzo Ferrari, LaFerrari, F60 America, Sergio, LaFerrari aperta, (category: Supercar, Limited Edition)
2. models: F512M, 550 Barchetta Pininfarina, Superamerica, 612 Sessanta, 599 GTO, SA Aperta, F12 TdF, Challenge Stradale, 430Scuderia, Scuderia 16M, 458 Speciale, 458 Speciale A, 488 Pista, 488 Pista Spider (Category: Special Series)
3. 8-cylinder engines
4. 12-cylinder engines

Every Ferrari car that undergoes unauthorized modifications by the parent company can no longer be considered a "Ferrari". The use of Ferrari badges on modified and / or altered cars after their placing on the market constitutes a violation of the Ferrari brands, sanctioned by the relevant regulations, as well as damaging the prestige of the same brands, the Ferrari name and the original cars of our Clientele.

For this reason, the modified Ferrari cars can not under any circumstances participate in the event, or any other activity promoted, organized or supported by Ferrari itself.

5.2.2 "MODERN" VEHICLES

The accepted vehicles will be placed into the following groupings:

- Grouping A: 8-cylinder engines
- Grouping B: 12-cylinder engines
- Grouping C: Special Series, Limited Edition, Supercars

Inclusion of vehicles into Grouping C excludes them from Groupings A and B.

Vehicles must be fitted exclusively with tyres approved for road use; in its original configuration, namely that provided by the manufacturer for normal road use which can also include accessories to embellish or improve comfort.

The cars may be without sports documents.

5.2.3 "HISTORIC" VEHICLES" – FROM 1958 TO 1990

Accepted vehicles will be divided into the following groupings:

- Grouping D: vehicles built from 01/01/1958 to 31/12/1969
- Grouping E: vehicles built from 01/01/1970 to 31/12/1990

The certificate of authenticity of the entered vehicle, issued by FERRARI CLASSIC, or a copy of the request for certification, must be enclosed with the registration form.

Vehicles must also be accompanied by one of the following valid sporting documents:

- ACI-CSAI Regularity of Historic Cars card;
- HTP FIA (Historic Technical Passport FIA);
- HTP CSAI (Historic Technical Passport CSAI);
- ASI homologation or identity certificate;
- Certificate of registration to the AAVS National Historic Register;
- FIA historic car regularity pass;
- FIVA Identity Card.

Regardless of the sport document presented for admission to the races, the configuration of the cars must conform to the criteria of the ACI Sport Regulation.

Cars entered by foreign crews, but not having the documents listed in this article, may be admitted with a declaration of conformity to the sports regulations, issued by the same competitors, given to and countersigned by the organisers.

5.2.4 The cars entered must comply with the periodic revision of the vehicles if required and in accordance with the provisions of the laws of the country of registration. If the country of registration does not provide for the periodic revision of the cars, the competitor must produce a self-declaration in which he must declare the lack of need for revision according to the laws of the country of registration and consequently, he will

declare to be able to circulate in his own country of origin having undergone all the technical checks to demonstrate the perfect efficiency of the car and all its devices. In the absence of this document the crew will not be able to pass the administrative checks.

5.2.5 REPLACEMENT OF A COMPETITION CAR

5.2.5.1 Conditions for substitution

An accepted vehicle may be substituted no later than 23:59 on **Friday September 18th 2020**. A car accepted may be substituted, following approval by the organiser, exclusively with a model which has all the requisites foreseen in these SRR/RPG. It will not be possible to replace any registered car after the time mentioned previously. The car replacements requested from **Friday September 18th 2020** will not be shown on the organizer's publications.

5.2.5.2 Requirements for requesting the substitution of a competition car

The substitution of the competition car must be notified by the competitor and the request must arrive by certified email (PEC) to the address 1000miglia@legalmail.it or by registered mail with return receipt to the address of the Company (1000 Miglia s.r.l. - Via Enzo Ferrari 4/6 - 25134 Brescia). The form requesting the substitution of the competition car must be accompanied by the documents stated in Article 5.3.6 in these SR.

The substitution of the competition car requires the mandatory payment of € 2.440,00 (i.e. € 2000,00 + VAT 22%) for administrative fees, payable to the IBAN number stated on the car substitution form. In the absence of such payment, the request for substitution will not be taken into consideration. The Organiser will contact the competitor within 10 days from receipt of the request for substitution, accompanied by the bank transfer.

5.2.6 The use of a temporary number plate is always prohibited, under penalty of immediate exclusion.

5.2.7 The following are always prohibited, subject to a penalty which may include exclusion, at the Stewards discretion:

- a) the installation and use of any protrusion from the bodywork, not envisaged by the Manufacturer, which has the purpose of sighting the intermediate split lines;
- b) installing or implementing viewfinders with adhesive material, inside or outside the vehicle, having dimensions larger than 15cm in length and 2cm in width;
- c) the presence of adhesive viewfinders on race number plates, on the Organiser's advertising stickers and on race number plates.

Article 6 - RACE NUMBER AND STARTING LIST

6.1 The assignment of Race Numbers, valid also for drawing up the Starting Order in relation to the increasing order of the numbers assigned, excepting for specific organisational requirements, will comply with the following criteria:

- cars in increasing order of year of manufacture.

6.2 Vehicles in the waiting list (Article 7.9) will leave according the race number assigned by the organiser who will, as far as possible, comply with the criteria stated in the previous points of this article.

ARTICLE 7 - ENTRIES

7.1 By signing the registration form the competitor and drivers undertake to keep only to the sports jurisdiction acknowledged by the International Sports Code and the provisions of these SRR.

Presentation of the registration form does not give the right to participate in the race as the organiser will select the requests and accept registrations in his unquestionable judgement.

The organisers will not be required to motivate the reason for exclusion, nor will the said exclusion allow for the request for damages and/or refund of expenses, excepting for the return of the deposit (Art. 7.6 of these SRR).



7.2 WAYS OF REGISTRATION AND WITHDRAWAL OF REGISTRATION

Registration must be sent, using the web application prepared by the organizer, to: 1000 MIGLIA s.r.l. - via Enzo Ferrari n. 4/6 - 25134 BRESCIA - Tel. +39 030 2318211 - Fax +39 030 2319288 - E-mail: ferrartribute@1000miglia.it

Registrations must be sent, on the days and the times stated in the Programme of these SRR, to ferrartribute@1000miglia.it accompanied by proof of payment of the fee as stated in Article 7.3 below, as a deposit.

The registration date of each competitor coincides with the date on which the deposit as stated in Article 7.3 below, is credited into the 1000 Miglia S.r.l. current account number.

Any request for withdrawal of registration must be received within the registration closing date, by means of registered e-mail (PEC) 1000miglia@legalmail.it or by registered mail with return receipt to the registered address of the company (1000 MIGLIA s.r.l. - via Enzo Ferrari n. 4/6 - 25134 BRESCIA). This request will allow the refund of the amount paid as a deposit net of administrative charges of Euro 183,00 (Euro 150,00 + IVA) within 60 days from date of notification of the withdrawal.

7.3 REGISTRATION GUARANTEE DEPOSIT

7.3.1 Payment of Euro 12.200,00 o Euro 14.640,00 depending on the selected service package, as a deposit for registration of the car and team must be done in one of the following ways:

- a) by Credit Card (only VISA - MASTERCARD) by 23:59 (GMT+1) on Friday **20 March** 2020;
- b) by bank transfer to the coordinates indicated in the registration form, with maximum credit value on the 1000 Miglia S.r.l. current account by 23:59 (GMT+1) on Friday **20 March** 2020.

For the entry to be valid, the crediting date onto the bank account of 1000 Miglia is considered and not that of the payment mandate.

7.4 ACCEPTABILITY OF REGISTRATION REQUESTS

Registration requests must be complete with all the necessary documentation, also photographic, accompanied by the greatest number of documents attesting the history of the registered vehicle, and the payment of the deposit.

Failure to pay the deposit means the request for registration will not be taken into consideration.

Requests which are untrue, incomplete, without documentation or with amounts owing to the organisation, will not be taken into consideration.

The organisation reserves the right not to accept vehicles whose drivers have been penalised in previous editions of the "Ferrari Tribute to 1000 Miglia".

L'organizzatore si riserva altresì la facoltà di non accettare l'iscrizione dei conduttori che per tre volte nell'arco della gara dell'anno precedente abbiano commesso infrazioni di superamento del limite di velocità stabilito dalle autorità preposte e rilevato dagli Speed Test predisposti dalla Direzione Gara.

7.5 ACCEPTANCE OF REGISTRATION

By Friday 27 March 2020 the starting list will be published online. Confirmation will nonetheless be sent also to the e-mail address indicated and published in the relative area of the registration form.

7.5.1 FINALISING REGISTRATION

Entry is understood as being finalised only on acceptance of the entry request by the organiser and to the allocation of the sum paid as a deposit in the sum paid as an entry fee.

After the car has been accepted at the event, 1000 Miglia Srl will issue a regular invoice, using the data requested during the entry phase.

By presenting the request for registration the applicant authorises the organiser to consider the amount paid previously as a deposit, as a registration fee in the case of acceptance of the request for registration.

7.5.2 ENTRY FEE

The following entry fees are envisaged:

1) **BASIC ENTRY IN DOUBLE ROOM:**

The Basic entry fee amounts to Euro 10,000.00 plus 22% VAT (total Euro 12,200.00) and includes:

- a) Participation in the competition after selection of the car:

Ferrari Tribute to 1000 Miglia 2020
Regolamento Particolare di Gara – Special Race Regulations



- kit of documents and technical materials provided;
 - Standard pass;
 - Welcome Bags and merchandising
- b) Hospitality for a crew of two persons, including:
- 3 nights in a double room (not less than 4 stars) with breakfast;
 - 4 light buffet lunch per person;
 - 3 light dinner per person;
 - Participation to the Charity Gala Dinner **TBD** for the driver and co-driver, only upon confirmation of participation not later than on the 15th April;
 - Ferrari Tribute Prize ceremony for driver and co-driver and admission to 1000 Miglia Closing Party Prize ceremony.
- c) Services included in the entry:
- 4 pass access to the paddock area (included driver and co-driver)
 - Pre-check-in service for hotels along the route (subject to credit card and passport delivery);
 - Possibility to purchase additional service packages.
- 2) **GOLD 1000 MIGLIA ENTRY IN DOUBLE ROOM**
The Gold entry fee amounts to Euro 12,000.00 plus 22% VAT (total Euro 14,640.00) and includes:
- a) Participation in the competition after selection of the car:
- kit of documents and technical materials provided;
 - "Gold" Pass;
 - Merchandising (2 Official Driver Jackets 1000 Miles 2020 - 2 Bags).
- b) Hospitality for a crew of two persons, including:
- 5 nights in a double room (not more than 4 stars) with breakfast;
 - 4 light buffet lunch per person;
 - 3 light dinner per person;
 - Participation to the Charity Gala Dinner **TBD** for the driver and co-driver, only upon confirmation of participation not later than on the 15th April;
 - Ferrari Tribute Prize ceremony for driver, co-driver and for 2 extra invitations; and admission to 1000 Miglia Closing Party.
- c) Services included in the entry:
- 4 pass access to the paddock area (included driver and co-driver)
 - Pre-check-in service for hotels along the route (subject to credit card and passport delivery);
 - Possibility to purchase additional service packages.

7.6 REFUND OF THE REGISTRATION FEE FOR CREWS NOT ACCEPTED

In the case of non-acceptance and/or non-inclusion on the waiting list of a car by the organiser, the deposit will be refunded by bank transfer or accredited on the credit card, by Thursday 30 April 2020.

7.7 WITHDRAWAL OF A REGISTRATION

A withdrawal of a competitor must be notified by CEM certified e-mail to 1000miglia@legalmail.it or by Registered Letter with acknowledgement of receipt to the registered head office of the Company (1000 Miglia s.r.l. - Via Enzo Ferrari, 4/6 - 25134 Brescia).

7.7.1 REFUND OF THE REGISTRATION FEE FOR WITHDRAWAL OF REGISTRATION

The refund (if due) of the registration fee in the case of withdrawal by a competitor will only come about in compliance with what is stated below:

- a) if the request for withdrawal of registration is notified by 23h59 (GMT+1) on **Friday September 18th 2020**, the registration fee will be refunded, amounting to 50% + VAT;
- b) if the request for withdrawal of registration is notified after 24h00 (GMT+1) on **Friday September 18th 2020**, the registration fee will be not refunded.

In any event the registration fee will be refunded within 60 days from the date of notification of the withdrawal.

7.8 FAILURE TO PASS PRE-RACE CHECKS

In the case of failure to pass the administrative and/or technical tests, the competitor will not have the right to the refund of the registration fee paid, but will retain the right to make use of the hospitality envisaged for the team and any gifts and gadgets distributed directly by the sponsors, as per Article 7.5.2 of these SSR. This right shall be guaranteed only if the competitor or a crewmember with proxy signed by the competitor

are present at the pre-race administrative checks. Therefore, if Competitors or drivers authorised by the same, are not present at the pre-race checks, they will not be entitled to the refund of the registration fee, nor will they be allowed to enjoy the hospitality provided for the crew or any benefit or facilities reserved to the participants.

7.9 WAITING LIST

The "Waiting List" is an instrument that allows the competitors registered for the event but not accepted by the Organiser at the posting of the entry list and anyway before Friday 27 March, to participate in the race by replacing crews that have withdrawn the checks for any reason.

At the presentation of the request for registration every competitor must state his acceptance to be placed on the waiting list.

The waiting list will be made up of the cars that:

- a) satisfy all eligibility requirements, and as checked by the Organizer;
- b) have not been accepted by Friday 27 March 2020;
- c) belong to competitors who have provided their willingness to be part of such list.

Should a competitor accepted for the race notify, from the posting of the Starting List, his withdrawal from the competition, the organiser, at his sole discretion, will select one of the competitors on the waiting list to replace the said withdrawing competitor.

7.9.1 RANKING LIST OF CARS ON THE "WAITING LIST"

There are no ranking lists for the cars on the waiting list. The replacement of crews that have withdrawn will be at the unquestionable discretion of the organiser.

7.9.2 CLOSURE OF THE "WAITING LIST"

The waiting list will close on Thursday **1st October** 2020 at 23:59.

By the said date, the Organiser will inform those teams on the "Waiting list" whether they have been accepted for the race, or not, by e-mail directly to the address stated in the relative section of registration form.

Acceptance by the Organisation will allow the team to be registered for the race in compliance with Article **7.5.1** of this RSS.

7.9.3 The organiser has the right to contact competitors on the "Waiting List" in the case of withdrawal, from Thursday **1st October** to **Wednesday 21 October** 2020.

Competitors on the "Waiting List" have the right to accept or reject the proposal to participate by replying to the e-mail address 1000miglia@legalmail.it within 24 hours from notification.

7.9.4 NOTIFICATION OF WITHDRAWAL OF A REGISTRATION OF CARS ON THE "WAITING LIST"

The withdrawal of a request for registration by a competitor on the "Waiting List" must be done by means of certified e-mail (CEM) to 1000miglia@legalmail.it or by registered mail with acknowledgement of receipt to the registered head office of the company 1000 Miglia s.r.l.

7.9.5 REFUND OF DEPOSIT FOR VEHICLES ON THE "WAITING LIST"

The refund of the deposit in the case of withdrawal by a competitor of a vehicle on the waiting list, will only occur in compliance with what is stated in Article 7.2 paragraph 4 of these SRR, applying administrative fees of Euro 488,00 (Euro 400,00 + VAT).

If owed, the deposit fee will be refunded within 60 days from the date of notification of the withdrawal, and nonetheless within and no later than Monday **30 November** 2020.

It remains firm that competitors who do not withdraw and are not selected from the "Waiting List" have the right to be refunded in full for the amount paid by bank transfer or accredited on their credit card by Monday **30 November** 2020.

Competitors entered in the waiting list are also given the right to use the guarantee deposit withheld by 1000 Miglia Srl for the 2020 edition as a guarantee deposit for the 2021 edition of the 1000 Miglia event, therefore 1000 Miglia srl will not provide for reimbursement by November 30th 2020.

In order to exercise this right, the participants must send a written notification to the address participants@1000miglia.it expressing this intention and stating their acceptance to pay any additional fee

in accordance with the Special Regulations of the 2021 edition of the race and formalizing the entry according to the web applications prepared by the organizer.

7.10 CANCELLATION OR SUSPENSION OF THE EVENT

In the occurrence of force majeure and other similar events outside their control, the Organisers reserve the right, at any time and in their unquestionable judgement, to postpone and/or cancel or suspend the race.

Should the cancellation and/or postponement be decided and notified before the publication of the list of cars accepted, the Organiser will refund 50% of the deposit paid to all the competitors who have properly filled in the registration form.

Should the cancellation and/or postponement be decided and notified after publication of the list of cars accepted, the Organiser will not refund the competitors registered or accepted for the race.

For those competitors on the "Waiting List" the terms of Article 7.9.5, fourth paragraph of these SRR will apply; for competitors not accepted, the provisions of Article 7.7.1 of these SRR will apply.

Article 8 - GENERAL OBLIGATIONS

8.1 PRE RACE CHECKS

8.1.1 ADMINISTRATIVE CHECKS

Competitors and drivers must be present in person and with the accepted car, failure to do so will imply the impossibility of passing the checks and therefore of participating in the race, in the ways and means established in the programme. The Sports Inspectors and Road Traffic Police will undertake the following checks and formalities:

- a) checking of mandatory documents for competitors and drivers to be presented in original copy:
 - valid driving license, national and international;
 - sports licence of the nation of belonging or Italian daily licence;
 - medical certificate (Article 5.1.9 of these SR);
 - valid competition car insurance;
 - competition car registration papers.
 - possible declaration of non-necessity of periodic revision of the vehicle according to the laws of the country of registration of the vehicle.
- b) hand out and apply the Personal Identification Device (CPI) described in Article 8.1.2 of these SRR
- c) sign, for acceptance, the check forms drawn up by the organiser and the Road Traffic Police;
- d) listening to or acknowledgement of the briefing by the organiser and the Clerk of the Course on the methods and procedures of the race, signing for acceptance of the contents.

8.1.2 PERSONAL IDENTIFICATION DEVICE (CPI)

During the pre-race administrative checks, each person will receive applied a Personal Identification Device (CPI), in order to clearly identify in unequivocal and incontrovertible way the participant for the entire duration of the event.

The staff delegated by the organiser will be responsible for the application of this device and this cannot be refused by the driver.

The device cannot be ceded and cannot be removed until the end of the competition on penalty of exclusion from the race.

The exhibition of the (CPI) can be requested by Officials or by escorting Road Traffic Police, at any moment. The absence of the sticker can result in the exclusion of the crew and the car from the race.

In the case of breakage or loss of the (CPI) the driver must first notify it to the first Competitor Relations Officer he finds along the route.

- ##### **8.1.3**
- Only members of crews who have passed the pre-race administrative checks can participate in the competition. No exchanges of authorised drivers are allowed between cars in the race.

Should persons other than those who have passed the pre-race administrative checks be found on board a competition car during the race, except for the transport of an injured person, the car and its driver will be immediately excluded from the race; this also does not exclude further penalties to be decided at the discretion of the Stewards.



8.2.1 RACE NUMBER STICKERS

At the administrative checks, each competitor will receive a Sticker Kit consisting of:

- 3 round number holder stickers, with the race number and the Organizer's advertising;
- 2 series of pre-spaced fluorescent race numbers.

8.2.2 APPLYING THE STICKERS TO THE CARS

Cars must be presented for technical checks with all the kit stickers mentioned in Article 8.2.1 of this SRR already applied, according to the following instructions:

- a) 1 round number holder sticker for each side of the competition car on the front doors (in cars with doors) or on the front sides (on cars without doors or with small doors);
- b) 1 round number holder sticker on the front bonnet of the competition car;
- c) 1 pre-spaced fluorescent number on the front windshield positioned to allow it to be seen when looking at the front part of the competition car;
- d) 1 pre-spaced fluorescent number on the rear window: should this not be possible the sticker must be applied on the rear boot in such a way as to allow it to be visible looking at the back of the competition car;

The guide layout is provided attached to these SRR, for the correct positioning of the race numbers (Attachment 3).

Should it not be possible to apply all three of the round number holder stickers that are distributed, on the cars due to lack of space, it will be possible to apply only 2 stickers. In this case the third sticker must be returned to the Organisation at the technical check, failure to do so could result in exclusion from the race.

8.3 SCRUTINEERING

After having passed all the administrative checks, the crews must submit the cars to scrutineering, in the ways and times stated in the programme. Failure to do so will lead to the cars being excluded from the race. Checks will be as follows.

- a) check of the correct positioning of the stickers in compliance with Articles 8.2.1 and 8.2.2 of these SRR and check of the sound and light signals suitable for travelling on the road;
- b) check of the following documents, to be presented as originals:
 - FIVA International Identity Card and/or FIA Heritage Certificate and/or valid ACI Sport Fiche (or requested) and/or HTP FIA concerning the competition car;
 - check that notified data correspond with registration data (year of manufacture and chassis number);
- c) placing of safety equipment as per Article 8.4 of these SRR.

8.4 SAFETY EQUIPMENT

The GPS tracker equipment supplied by the organiser must remain installed on the competition car for the entire duration of the race. The equipment must be returned to the CO/TC at the final arrival.

The device will be pre-installed during the technical checks by specific technicians (a strip of Velcro will be applied on the vehicle to fix the device) and all necessary information as well as a use manual for the device will be provided, as well as a release form for the use of data recorded on the device itself.

The "GPS Tracker" will track compliance to the route of the race by the team and will also record the speed of the car. Recorded data will be available to the Race Directors and Stewards in order for them to take disciplinary action against the competitors who have broken the Road Safety Rules and the race regulations, aside from any other provisions that could be taken by Police Officers who have detected an infringement of the law. Data could be made available following a request by the legal authorities.

Data held by the Organiser will be stored in compliance with the Law of 8 April 2010 "Provisions in matters of video-surveillance".

In the case of loss or malfunction of the device the competitor will notify this to the Competitor Relations Officer at every T.C. or those responsible for technical devices present at every lunch break and every arrival/start of each Leg.

In the case of withdrawal of a competitor along the route of the various stages, the device will be returned to the Competitor Relations Officers or to the persons responsible for this in the Technical Support Convoy (Technical Car and Pace Car).



8.5 OBLIGATIONS OF COMPETITORS

Throughout the event, drivers must drive prudently and carefully, scrupulously respect the Italian Road Traffic Law and instructions given by the Clerk of the course and by Race Officials.

The Race Officials - those in Charge (Article 2 of these SRR) positioned in the Technical Support convoy (teams in the Front Car, Pace Car and Technical Car) and Road Traffic Police Officers will notify violations and offences of the Regulations and the Instructions stated above.

In the case of infringements, the Clerk of the course will notify the Stewards who will apply the following penalties:

- first offence: 1.000 negative penalty points;
- second offence: 12.000 negative penalty points;

Depending on the seriousness of the offence, the Stewards will apply the penalties up to exclusion from the event, even after only one offence.

In each Lap the Race Director can undertake speed checks on all the cars in the race.

The Organiser reserves the right not to accept cars whose drivers have been penalised in previous editions of the 1000 Miglia event.

The organizer also reserves the right not to accept the entry of drivers who for three times during the previous year's race have committed infractions of exceeding the speed limit established by the authorities in charge and detected by the Speed Test prepared by the CoC.

The Race Officials along the route as well as all the cars in the Technical Support convoy (Article 2 of these SRR, teams in the Front Car, Pace Car and Technical Car) and Road Traffic Police Officers will also be responsible for supervising the conduct of the competitors and their service and team vehicles, notifying the Clark of the course of any offence but without taking any independent decisions.

Also, Road Traffic Police Officers and local Police Forces in the relative areas can notify the Clark of the course of any offences by competitors and their service and team vehicles.

Driving behaviour should always be prudent for oneself, for Officials, and especially for spectators.

Each competitor is always responsible also for the behaviour of their service and team vehicles, which must necessarily strictly observe the instructions given by Officials and Marshals and must follow the route envisaged in the Road book in some parts of the race route. Failure to comply with this provision will result in sanctions against the relevant competitor, and may even lead to expulsion from the race, at the Stewards discretion.

8.6 CHECKING OF PERSONAL IDENTIFICATION DEVICE (CPI)

For the entire duration of the event, the Officials on duty can ask the drivers to see their CPI (see Article 8.1.2 of these SRR). Drivers that cannot show their stickers could be expelled from the competition by the Stewards.

Article 9 - RUNNING OF THE RACE

9.1 START

The cars will leave one at a time, from a stationary position with the engine running, three cars departing every minute. Each car, once they have been given the "go", will have to free the Departure area as quickly as possible.

Under the control of Officials, departure may take place by pushing the car, if it fails to leave on its own.

Competitors must not stop the competition car in the control areas (between the areas signalling the Start and End areas), exception being made for the check areas where the authorisation stamp will be printed by the Officials, reversing, changing direction, opening doors and in any way hindering the other teams will lead to the application of the penalty as stated in Article 11 of these SRR.

The teams that do not make the CO/TC 1 Brescia - Departure Leg 1, will be penalized as specified in Article 11 of these SRR for each missed transit check. Transit at CO/TC of the Leg 2 - Departure will still be mandatory, under penalty of exclusion.



Drivers must keep to the Official Race Times stated in the Itinerary Table. No restrictions will be imposed on them as regards the use of time recording equipment. The same may be synchronized with the clock placed at the start of each Leg, without direct connection to the said clock.

Any defect in detection of times, caused by any failure or malfunction of the equipment, will result, for the said checks, in the application of the average to each competitor and/or the annulment of the checks themselves for all competitors.

The organisers will state in the Road book, and this will also be indicated on site, a straight stretch of road with measurements, used as the measured base in the preparation of the Road book, and competitors can verify this before the race.

9.2 TIME CONTROLS (CO/TC)

The purpose of the Time Control (CO/TC) is to outline the areas in which the route of the race is divided, in order to regulate the conduct of the same and to make sure the average speed is respected.

Each competitor (even when 3 cars a minute have been planned for) must be measured on the minute (e.g. for transit time 14:01 it will be possible to transit without penalty from 14:01:00 to 14:01:59). The excesses as regards the ideal times established will determine the classification.

Penalties for delays and early arrivals at a CO/TC are those stated in Article 11.1.1 of these SRR.

Delays and early arrivals at a CO/TC must not be caught up in the next CO/TC. Teams must leave the "check area" free for transit. They are authorised to enter this area on board their car, in the minute preceding the ideal one for transit, and remain in the area for the time strictly necessary to record the transit time. When the time is being read, the car must be inside the time reading area.

During reading operations at least one member of the team must be on board the competition car.

The time used for the reading operation is not neutralised in any way. The reading is taken at the moment when one member of the team hands over the Time Card to the Time-keeper.

In the case where competition cars that are late or in advance of their ideal times transit through the CO/TC in the minute pertaining to cars on time, the Time-keeper will make a note, on the Time Card of the team that is late or in advance, of the real transit time, which corresponds to the start of the next sector, giving precedence, in the marking operations, to the team with the less delay on the ideal transit time.

All the CO/TCs will be appropriately marked with signs in compliance with the examples attached to these SRR (Attachment 6).

Vehicles transiting through a CO/TC in the opposite direction or a direction other than the one decided by the organiser, will be excluded from the race.

9.3 TIME TRIALS (PC/TT)

Time Trials (PC/TT) are those timed areas of the route, between two consecutive readings where the drivers must keep to a set time indicated in the Itinerary Table and in the Time Card.

Readings will be done at 1/100th of a second without any tolerance. Differences in the ideal time will, as for the differences read at CO/TC, be used in determining the classification.

PC/TT will be undertaken with departure read at free entrance; the driver will be able to freely choose the start of the PC, nonetheless within approx. 5 seconds from the "all clear" given by the Marshals and/or the Time-keeper in charge.

Various consecutive PC/TTs will be envisaged (interconnected), where the time for passing to the final reading of the previous PC/TT will be the start time of the next PC/TT, and so forth.

For PC/TT located in equipped areas or temporary circuits, race tracks, kart racing tracks, and for PC/TTs with lengths less than 300m, an appropriate map will be attached with the Road Book.

All PC/TTs will be properly marked both at the start and at the end, with signs in compliance with the examples attached to these SRR (Attachment 6).

In the area of the route between the yellow sign and the beige sign showing the start and end of the measuring area, cars are not allowed to park, stop or open the doors. Should any cars stop in this measuring area due to a breakdown, they must be immediately removed according to the instructions given by the race official, on penalty of exclusion. Furthermore unauthorised access by drivers and navigators is also forbidden.



Vehicles transiting through a PC/TC area in the opposite direction than the one decided by the organiser, will be excluded from the race.

In the event of failure to carry out one or more TT or should there be no result for the same, for whatever reason, the competitor(s) concerned will receive a penalty of 300 points for each TT not undertaken or lacking a result.

The application will be implemented on completion of the TT concerned, unless the competitor/s officially communicate/s his/their withdrawal from the race.

This provision does not apply in the case of "awarding of the average" by the Clerk of the Course following the report of the Stewards responsible for the posts where the events occurred.

9.4 AVERAGE TRIALS (PM/AT)

Average Trials (PM/AT) are those areas of the route within a sector, where drivers must keep to a set hourly average, stated in the Itinerary Table and the Time Card.

For each PM / AT, for the purposes of classification of the trial, all the detections carried out be considered, then proceeding to the calculation of the average penalty.

The Road book will state the start area and the place of the maximum real limit of end of the PM/AT. In the area from the start to the end of the PM/AT, the average is taken at one or more points not known to the driver.

The Itinerary Plan will state the number of readings envisaged for each PM/AT. Every Average Trial could plan up to 5 readings.

The exit time is read in seconds, manually, with writing equipment.

9.4.1 START OF AVERAGE TRIALS

- a. the start time of the PM/AT is free and coincides with the passage on the pressure gauge on the start line;
- b. the transit time on the pressure gauge will be lapped manually by the Time-keepers assigned for the purpose, will measured to the second lapsed.

9.5 PASSAGE CONTROLS (CT/PC)

The purpose of the Passage Controls (CT/PC) is to check the strict adherence to the established route.

The opening and closing times of the CT/PC will be notified by the Clerk of the course Bulletin. At the CT/PCs, drivers must stop the cars in order for the check stamp or "all clear" stamp to be printed in the relative area of the Time Card. The absence of this stamp will mean exclusion.

All the CT/PC areas will be properly marked with signs in compliance with the examples attached to these SR (Attachment 6).

Vehicles transiting through a CT/PC area in the opposite direction or one other than the one decided by the Organiser, will be excluded from the race.

9.6 ARRIVAL

Arrival check will be in Brescia - Piazzale Iveco and will be open from 15:10 on **Sunday 25 October** 2020.

After the arrival CO/TC competitors will proceed following the instructions given by Marshals, to the arrival ramp.

Article 10 - MAXIMUM LATENESS

A crew will be over the maximum lateness:

- if it transits through a Time Control (CO/TC) with more than 30 minutes delay.
- if it accumulates delays through various Time Controls totalling more than 60 minutes delay.

Only at the starting CO/TC of each Leg will a crew be considered over the maximum time limit if they transit with more than 15 minutes of delay.

Ferrari Tribute to 1000 Miglia 2020
Regolamento Particolare di Gara – Special Race Regulations



The opening and closing times of the Time Trials (PC/TT), the Average Trials (PM / AT) and of the Print Checks (CT /CP) will be notified through a Clerk of the course Bulletin.

Article 11 - PENALTIES AND DISCIPLINARY MEASURES

11.1.1 - Time checks (CO/TC)

- for every minute or fraction thereof early: 100 negative penalty points
- for the first 2 minutes or fraction thereof late: 25 negative penalty points
- For more than 2 minutes and up to 5 minutes: 50 negative penalty points
- For delay of more than 5 minutes and up to 10 minutes: 100 negative penalty points
- Over 10 minutes and up to 20 minutes: 200 negative penalty points
- For over 20 and up to 30 minutes: 300 negative penalty points
- For each delay beyond the maximum time: 12,000 negative penalty points

11.1.2 - Time Trials (PC/TT)

- for each 1/100 of second early or late: 1 negative penalty point

11.1.3 - Average Trials (PM/AT)

- for every second late: 1 negative penalty point
- for every second early: 1 negative penalty point

11.1.4 - Secret Transit Checks

- up to 20 minutes early: 320 negative penalty points
- more than 20 minutes early: 12.000 negative penalty points
- 2nd time more than 20 minutes early: exclusion

11.1.5 - Time Card

- alterations, changes or corrections not endorsed by Race Officials: exclusion
- Failure to record a CO/TC: 12.000 negative penalty points
- Lack of a control stamp (CT/PC): 12.000 negative penalty points
- Failure to return to the CO/TC of Leg arrival: exclusion

11.1.6 - Other Penalties

- refusal to start at the hour and in the set order: 100 negative penalty points
- stopping the car in the control area (stationary wheel): 100 negative penalty points
- unauthorised access of the crew in the check area (subject to further action): 300 negative penalty points
- missing transit or time annotation at any control point: 12.000 negative penalty points
- unauthorized stopping in a control area: 12.000 negative penalty points
- blocking the passage and/or damaging other crews: exclusion
- for non-sportsmanlike behaviour: from warning to exclusion
- for passage in a control area in a wrong or different direction: exclusion
- for infringements of the Road Safety Rules: up to exclusion
- document irregularities during administrative checks: non-acceptance
- failure to comply with the checking times: up to non-acceptance
- not starting at the first and the second Stages: exclusion
- allowing a person other than a crew member to drive the car: exclusion
- lack of a race number or race license plate: fine
- lack of two or all of the competition numbers: exclusion
- failure to comply with provisions concerning the synchronization of chronometers: up to exclusion
- for non-prudent behaviour of a crew member, or assistants or team car: up to exclusion
- for leaning out of a moving car: up to exclusion
- Failure to comply with the orders of Officials and Marshals: up to exclusion
- Article 8.6 - first offense: 1.000 negative penalty points
- Article 8.6 - second offense: 12.000 negative penalty points
- Article 8.6 - third offence: exclusion
- infringements of the rules on advertising on cars in the race: 12.000 negative penalty points



Article 12 - CLASSIFICATION-PROTESTS AND APPEALS

12.1 CLASSIFICATION

The following standings will be drafted:

There will be an overall classification including all the cars admitted to the competition called "General Ferrari Tribute to 1000 Miglia 2020".

"Modern" Vehicles – from 1991 to today (art. 5.2.1)

"Historic" Vehicles – until 1990 (art. 5.2.2)

12.2 COMPILATION AND PUBLICATION OF RESULTS

Classifications will be drafted on the basis of points scored by each crew in the PC/TT, in the PM/AT, the CO/TC and calculated according to the "points table" (Attachments 8 and 9) and the coefficient assigned to each car (Attachment 7), deducting any possible negative penalty points.

"Differences" are not provided for.

The crew that receives the highest number of points will be declared the winner.

In case of a tie in the final ranking, the winning position will be awarded to the crew/crews that has/have accumulated the least number of penalties, not points, during the race.

Those crews that do not transit or do not hand in the Time Card to the final arrival point (the arrival Leg 4), will not be classified.

The results will be published as per the Programme.

12.3 COMPLAINTS AND APPEALS

Complaints and appeals must be submitted in the manner and within the terms established by the National Sporting Regulations.

- For each complaint, the security deposit is € 350.00.
- For each appeal, the security deposit is € 3.000,00.

12.3.1 TERMS FOR SUBMISSION OF COMPLAINTS OR REQUESTS OF TIME CHECK

The rankings compiled at the end of Stages 1, 2 and 3 are to be considered final in the elements used to complete them. These classifications will be published 30 minutes before the start of each Leg: competitors may submit a complaint (including a request of timing verification) against published documents, until the time of their individual starts by presenting a document with reasons for the dispute to the Competitor Relations Officers present at the start.

Article 13 - PRIZES

The event will have the following honour prizes:

Classification "Overall Tribute to 1000 Miglia 2020" among all eligible vehicles (Art. 12.1.a)

- For the first 3 classified;

"Modern" vehicles – from 1991 to today (art. 12.1.b)

- For first place of the group classification;

"Historic" vehicles – until 1990 (art. 12.1.c)

- For first place of the group classification.

- Other Prize:

The Prize "5° Stefano Rabbito Trophy" will be awarded in the Roma Ramp to the first crew classified in the "Overall Tribute to 1000 Miglia 2020" classification considered at the CO/TC 8 Roma /Villa Borghese (excluded eventual penalties at that CO/TC)

The prizes are not cumulative, so the winners more than one ranking will only be awarded the prize of the most important ranking.

Crews that are not present at the prize-giving will forfeit their prizes without the classification is changed. Honour prizes will be awarded to all classified crews.



Article 14 - GENERAL RULES

14.1 RESPONSIBILITIES

By the very act of registering for this event, each competitor declares for themselves and their drivers, for the staff on their own service vehicles and accompanying vehicles, for their dependents and assignees:

- to recognize and accept the provisions of the National Sporting Regulations (and Sector Rules) and the present SR, committing themselves to respect and to enforce them;
- to undertake to resolve any controversy which may arise from the Organisation and the conduct of the event by means of the mechanisms and methods of resolution provided for by ACI, waiving any other authority other than sport authorities for the protection of their rights and interests and those of their drivers, navigators, employees and agents;
- to relieve the Italian Automobile Club, the ACI Sport, the ACI Brescia, the Organiser 1000 Miglia S.r.l. and all persons involved in the organisation, as well as the Automobile Clubs involved in the event.

The Officials and the owners of the routes where the competition takes place from any liability regarding any damages to competitors, or their drivers, navigators, employees and agents, or things, or produced or caused to third parties or of objects by the competitor himself, his drivers, navigators, employees and agents.

14.2 ADVERTISING

No form of advertisement may be placed on the car, unless this is expressly provided for by the organiser, which will be announced by a special information bulletin, in compliance with the provisions of current ACI Sport legislation.

The names of the crew members can be written on each of the sides of the competition cars in the maximum dimension of cm. 10x40 per side.

A Club logo, not having advertising purpose (all or part thereof), can appear on each side of competition cars occupying a maximum space of cm. 10x10, per side or equivalent surface.

The original livery is tolerated as regards identification badges, even if they constitute advertising, limited however to what was originally used for that specific vehicle identified with the chassis number.

Any form of advertising that does not correspond to what is stated in this article will be removed by the Organiser and/or by Officials who will carry out checks before and during the race.

The breach of the provisions of this article will be sanctioned with 12,000 negative penalty points. Those crews that will be found non-compliant with the provisions set forth above will be denied participation in future editions of the event. The organiser reserves the right to charge the offending crew with damages resulting from the contravention of this Article.

The participants therefore agree to assume the obligation to pay compensation for all damages suffered by the organiser and third parties in general, relieving the same from any liability, for any and all liability and/or damages resulting from the violation of the abovementioned prohibition.

14.3 RACE NUMBER PLATES

All the race numbers (plates) handed over by the Organiser to the competitor, must be attached to the competition cars. The discovery of one of the delivered race number plates on a car other than the competition car, will lead to a penalty that could result in the immediate exclusion of the same competition car from the race.

Article 15 - INSURANCE

The Organizer adheres to the current sporting insurance policy: the Ferrari Tribute to 1000 Miglia 2020 race is covered by the CL Insurance Policy provided for in Article 56 of the RNS ACI Sport.

In this context, he confirms that he is fully aware that the CL policy, as mentioned in Article 56 of the RSN, complies with the regulations provided for in Article 124 of the insurance code, with minimum legal requirements, integrated by the organiser of 1000 Miglia S.r.l. up to the following limit of liability by type of risk:

- a) RCT (CLR) insured limits of liability – Civil Liability Risks (Third Parties)
 - € 15.000.000,00 per accident, with the limit of:

Ferrari Tribute to 1000 Miglia 2020
Regolamento Particolare di Gara – Special Race Regulations



- € 15.000.000,00 for personal damages, regardless of the number of people involved, and of
 - € 15.000.000,00 for damages to objects and animals
- b) RCO insured limits of liability – Organiser Risks
- € 15.000.000,00 per accident
 - € 15.000.000,00 per person

This policy does not relieve the Competitors and drivers from any liability they could incur beyond the object of the insurance and additional general and special policy conditions as published on the federal site and nonetheless requested from the Insurance Company.

The liability insurance of the Organisers will be operational, for each competitor, from the moment of completion of its administrative checks and will cease upon arrival or at the time of closing of the Time Control subsequent to that in which the competitor has withdrawn.

Article 16 - ATTACHMENTS

The following attachments are an integral part of these special race regulations:

- **ATTACHMENT 1:** Facsimile of the Medical Certificate for non-competitive sports activities;
- **ATTACHMENT 2:** Facsimile of the Medical Certificate for competitive sports activities;
- **ATTACHMENT 3:** Positioning of Race numbers on the cars;
- **ATTACHMENT 4:** Itinerary Table: (the definitive Itinerary Table will be communicated with the Road book);
- **ATTACHMENT 5:** Maps of the route: (will be communicated with the Road book);
- **ATTACHMENT 6:** Signage Posters of Checks;
- **ATTACHMENT 7:** Points table for the Time Trial (TT);
- **ATTACHMENT 8:** Points table for the Average Tests (AT).

Ferrari Tribute to 1000 Miglia 2020
Regolamento Particolare di Gara – Special Race Regulations



Special Regulations for the Grand Event for historic cars to be held on **19/25 October** 2020 called FERRARI TRIBUTE TO 1000 MIGLIA 2020.

The LEGAL REPRESENTATIVE states that modifications to the Special Regulations of the type drawn up by ACT have been done.

The Clerk of the Course
(has read and accepts the appointment) Lucio DE MORI _____ signed _____

The legal representative of the Organising Body Alberto PIANTONI _____ signed _____

For the Regional Delegation Alessandro TIBILETTI _____ signed _____

SEEN AND APPROVED
THE SECRETARY OF ACI SPORTS BODIES
Marco FERRARI

_____ signed _____

These SR have been approved on **05/02/2020** with approval number **RM/2/20**.

Ferrari Tribute to 1000 Miglia 2020
Regolamento Particolare di Gara – Special Race Regulations



Allegato 1: Fac-simile Certificato Medico Attività Sportiva non agonistica

Legge n°125,art.4,comma 10 septis e Decreto Ministero della Salute dell'08 agosto 2014

Certificato di idoneità alla pratica di attività sportiva di tipo non agonistico

Sig.ra / Sig.....

Nata/o a il

residente a.....

Il soggetto, sulla base della visita medica da me effettuata,dei valori pressione arteriosa rilevati,nonché del referto del tracciato ECG eseguito in data, non presenta controindicazioni in atto alla pratica di attività sportiva non agonistica.

Il presente certificato ha validità annuale dalla data del rilascio.

Luogo.....

data.....

il Medico

.....

timbro con codice identificativo e firma

Attachment 1: Facsimile Medical Certificate for non-competitive Sporting Activities

Law n° 125, art.4, para.10 septis and Ministry of Health Decree of 8 August 2014

Certificate of Fitness for non-competitive sporting activities

Mr/Ms.....

Born in..... on.....

Resident in

The individual, on the basis of a medical examination carried out by myself, including arterial blood pressure readings and ECG, carried out on....., does not present any current contraindications to non-competitive sporting activities.

This certificate is valid for one year from the date of issue.

Place.....

Date.....

The Doctor

.....

Stamp with identification code and signature

Ferrari Tribute to 1000 Miglia 2020
Regolamento Particolare di Gara – Special Race Regulations



Allegato 2: Fac-simile Certificato Medico Attività Sportiva agonistica

Regione U.S.L.

Certificato di idoneità
all'attività Sportiva Agonistica
(Art. 5 - D.M. 18.2.82)

Certificato N°

Cognome

Nome

Nato a

il

Residenza e/o domicilio

Documento d'identità

Sport per cui è richiesta la visita

L'atleta di cui sopra sulla base della visita medica e dei relativi accertamenti non presenta controindicazioni
in atto alla pratica dello sport

Il presente certificato ha validità di

e scadrà il

Data

IL MEDICO

.....
TIMBRO CON CODICE IDENTIFICATIVO E FIRMA

Attachment 2: Facsimile Medical Certificate for competitive Sporting Activities

Region USL

Certificate of Fitness
for Competitive Sporting activities
(Art. 5 – D.M. 82.2.82)

Certificate N°

Surname

Name

Born in

On

Resident and/or Domicile in

Identity Document

Sport for which the examination is requested

The abovementioned athlete, based on the medical examinations carried out and the relative results, does not present any current
contraindications for the following sport

.....
This certificate is valid for

And will expire on

Date

THE DOCTOR

.....
STAMP WITH IDENTIFICATION CODE AND SIGNATURE

Allegato 3: Posizionamento Numeri di Gara sulle vetture
Attachment 3: Positioning of Race Numbers on the cars

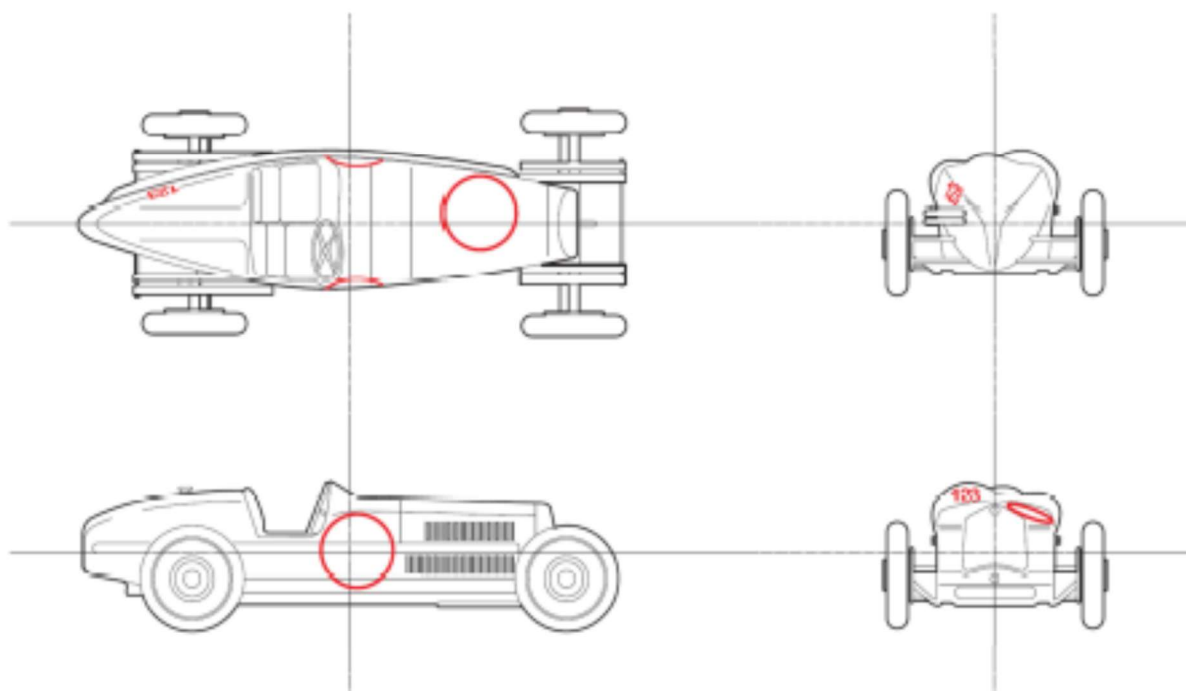
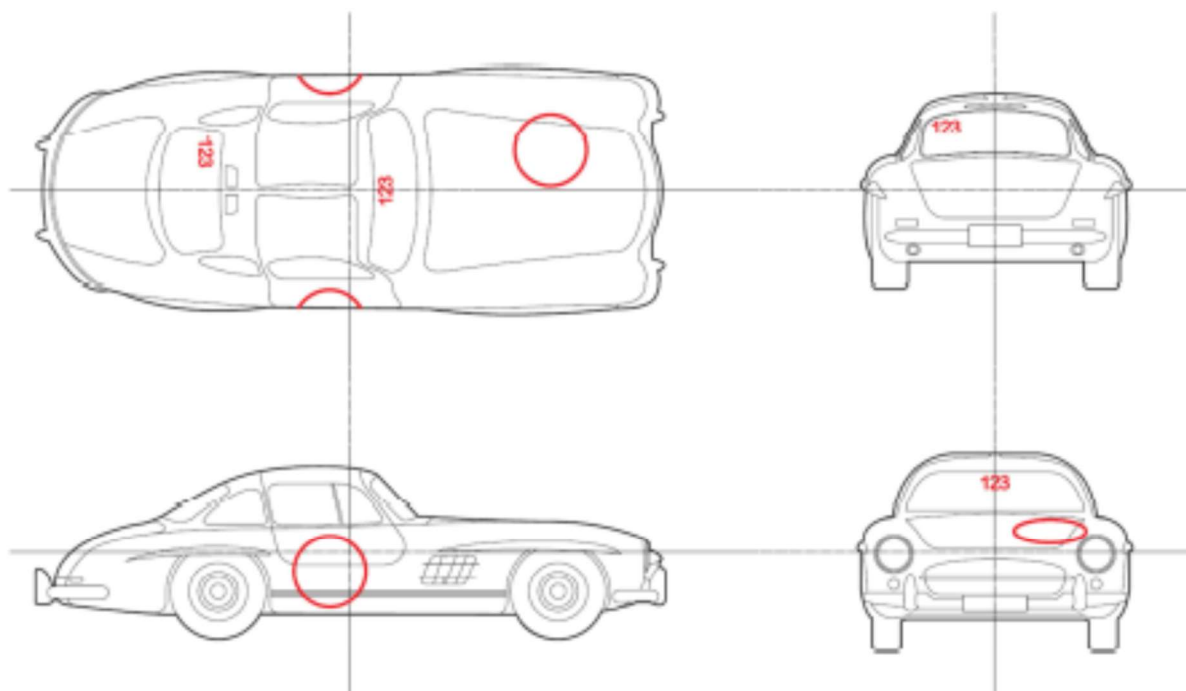

Allegato 4: Tabella Tempi e Distanze - La TDT ufficiale e finale sar  disponibile nel Road Book
Attachment 4: Time and Distance Table - The official and final TDT will be available in the Road book



Allegato 5: Mappa del Percorso di Gara
Attachment 5: Map of the route



Allegato 6: Cartellonistica dei controlli
Attachment 6: Control Signs

CARTELLI DEI CONTROLLI - CONTROL SIGNS

CO / TC *	<p>INIZIO ZONA CONTROLLO • CONTROL AREA START</p> <p>GIALLO/YELLOW</p> <p>mt 25 circa - approx.</p>	<p>CONTROLLO • CONTROL</p> <p>ROSSO/RED</p> <p>mt 25 circa - approx.</p>	<p>FINE ZONA CONTROLLO • CONTROL AREA END</p> <p>BEIGE</p> <p>mt 25 circa - approx.</p>	CT / PC **	<p>INIZIO ZONA CONTROLLO • CONTROL AREA START</p> <p>GIALLO/YELLOW</p> <p>mt 25 circa - approx.</p>	<p>CONTROLLO • CONTROL</p> <p>ROSSO/RED</p> <p>mt 25 circa - approx.</p>	<p>FINE ZONA CONTROLLO • CONTROL AREA END</p> <p>BEIGE</p> <p>mt 25 circa - approx.</p>
	<p>INIZIO ZONA CONTROLLO • CONTROL AREA START</p> <p>GIALLO/YELLOW</p> <p>mt 25 circa - approx.</p>	<p>CONTROLLO • CONTROL</p> <p>ROSSO/RED</p> <p>mt 25 circa - approx.</p>	<p>FINE ZONA CONTROLLO • CONTROL AREA END</p> <p>BEIGE</p> <p>mt 25 circa - approx.</p>				
PC *** SINGOLE O CONCATENATE LUNGHEZZA INFERIORE / UGUALE A 300 MT.	<p>INIZIO ZONA CONTROLLO • CONTROL AREA START</p> <p>GIALLO/YELLOW</p> <p>mt 25 circa - approx.</p>	<p>CONTROLLO • CONTROL</p> <p>ROSSO/RED</p> <p>lunghezza inferiore/uguale - length inferior/equal to 300mt.</p>	<p>FINE / INIZIO PC • END / START TT</p> <p>ROSSO/RED</p> <p>lunghezza inferiore/uguale - length inferior/equal to 300mt.</p>	PC *** SINGOLE O CONCATENATE LUNGHEZZA SUPERIORE A 300 MT.	<p>INIZIO ZONA CONTROLLO • CONTROL AREA START</p> <p>GIALLO/YELLOW</p> <p>mt 25 circa - approx.</p>	<p>CONTROLLO • CONTROL</p> <p>ROSSO/RED</p> <p>mt 25 circa - approx.</p>	<p>FINE ZONA CONTROLLO • CONTROL AREA START</p> <p>BEIGE</p> <p>mt 25 circa - approx.</p>
	<p>INIZIO ZONA CONTROLLO • CONTROL AREA START</p> <p>GIALLO/YELLOW</p> <p>mt 25 circa - approx.</p>	<p>CONTROLLO • CONTROL</p> <p>ROSSO/RED</p> <p>mt 25 ca - approx.</p>	<p>FINE ZONA CONTROLLO • CONTROL AREA START</p> <p>BEIGE</p> <p>mt 25 circa - approx.</p>				
TT **** SINGLE OR CONNECTED LENGTH INFERIOR / EQUAL TO 300 MT.	<p>INIZIO ZONA CONTROLLO • CONTROL AREA START</p> <p>GIALLO/YELLOW</p> <p>mt 25 circa - approx.</p>	<p>CONTROLLO • CONTROL</p> <p>ROSSO/RED</p> <p>lunghezza inferiore/uguale - length inferior/equal to 300mt.</p>	<p>FINE / INIZIO PC • END / START TT</p> <p>ROSSO/RED</p> <p>lunghezza inferiore/uguale - length inferior/equal to 300mt.</p>	PC *** SINGOLE O CONCATENATE LUNGHEZZA SUPERIORE A 300 MT.	<p>INIZIO ZONA CONTROLLO • CONTROL AREA START</p> <p>GIALLO/YELLOW</p> <p>mt 25 circa - approx.</p>	<p>CONTROLLO • CONTROL</p> <p>ROSSO/RED</p> <p>mt 25 circa - approx.</p>	<p>FINE ZONA CONTROLLO • CONTROL AREA START</p> <p>BEIGE</p> <p>mt 25 circa - approx.</p>
	<p>INIZIO ZONA CONTROLLO • CONTROL AREA START</p> <p>GIALLO/YELLOW</p> <p>mt 25 circa - approx.</p>	<p>CONTROLLO • CONTROL</p> <p>ROSSO/RED</p> <p>mt 25 ca - approx.</p>	<p>FINE ZONA CONTROLLO • CONTROL AREA START</p> <p>BEIGE</p> <p>mt 25 circa - approx.</p>				
PM PROVA DI MEDIA CON UNO O PIU' CONTROLLI SEGRETI	<p>INIZIO ZONA CONTROLLO • CONTROL AREA START</p> <p>GIALLO/YELLOW</p> <p>mt 25 circa - approx.</p>	<p>CONTROLLO • CONTROL</p> <p>ROSSO/RED</p> <p>estensione della prova di media / extension of average test</p>	<p>LIMITE DELL'ESTENSIONE DELLA PM - LIMIT AT EXTENTION</p> <p>ROSSO/RED</p>	AT AVERAGE TEST WITH ONE OR MORE SECRET CONTROLS	<p>INIZIO ZONA CONTROLLO • CONTROL AREA START</p> <p>GIALLO/YELLOW</p> <p>mt 25 circa - approx.</p>	<p>CONTROLLO • CONTROL</p> <p>ROSSO/RED</p>	<p>LIMITE DELL'ESTENSIONE DELLA PM - LIMIT AT EXTENTION</p> <p>ROSSO/RED</p>
	<p>INIZIO ZONA CONTROLLO • CONTROL AREA START</p> <p>GIALLO/YELLOW</p> <p>mt 25 circa - approx.</p>	<p>CONTROLLO • CONTROL</p> <p>ROSSO/RED</p>	<p>LIMITE DELL'ESTENSIONE DELLA PM - LIMIT AT EXTENTION</p> <p>ROSSO/RED</p>				

***Ai Controlli Orari NON SEGUITI da Start Prova Cronometrata**

Le vetture sono autorizzate ad entrare nella zona di controllo (tra il cartello giallo e quello rosso di controllo) nel minuto che precede il loro minuto teorico di transito (solo se la zona è già stata liberata dalle vetture che precedono) oppure nel loro minuto teorico di transito e devono consegnare la tabella di marcia al cronometrista, per l'annotazione dell'orario di transito. I membri dell'equipaggio sono autorizzati a rimanere a bordo della vettura.

****Ai Controlli Timbro**

I membri dell'equipaggio devono rimanere a bordo della vettura e consegnare al commissario la tabella di marcia, per l'apposizione del timbro, senza iscrizione dell'orario di transito; la sosta nella zona deve essere limitata all'operazione di timbratura.

*****Nelle Prove Cronometrate**

Tra il cartello giallo di inizio ed il cartello beige di fine zona controllo è vietato l'arresto (fermo vettura/fermo ruote) e la sosta della vettura.

***At the Time Controls NOT FOLLOWED by Start Time Trials**

The cars are authorized to enter the control area (between the yellow and red control sign) in the minute preceding their theoretical transit minute (only if the area has already been freed from the cars ahead) or during their theoretical transit minute and must hand in the time card to the timekeeper, in order for him to note down the transit time. Crew members are allowed to remain on board the car.

****During the Time Trials**

Between the yellow sign at the beginning and the beige sign at the end of the control area, it is forbidden to stop (vehicle stopped/wheels stopped) and park the car.

*****At the Stamp Controls**

The crew members must remain on board the car and hand in the time card to the Marshal, where he will put the stamp, without inscription of the transit time; parking in the area must be limited only to the stamping operation.

Ferrari Tribute to 1000 Miglia 2020
Regolamento Particolare di Gara – Special Race Regulations



Allegato 7: Tabella dei punteggi per le Prove Cronometrate - Points table for the Time Trial(PC/TT)

FERRARI TRIBUTE TO 1000 MIGLIA 2020

POINTS TABLE FOR THE TIME TRIAL

centesimi di secondo		centesimi di secondo		centesimi di secondo		centesimi di secondo	
penalità	punti	penalità	punti	penalità	punti	penalità	punti
0	420	42	158	84	116	126	74
1	395	43	157	85	115	127	73
2	370	44	156	86	114	128	72
3	350	45	155	87	113	129	71
4	330	46	154	88	112	130	70
5	310	47	153	89	111	131	69
6	291	48	152	90	110	132	68
7	272	49	151	91	109	133	67
8	254	50	150	92	108	134	66
9	236	51	149	93	107	135	65
10	226	52	148	94	106	136	64
11	217	53	147	95	105	137	63
12	212	54	146	96	104	138	62
13	207	55	145	97	103	139	61
14	203	56	144	98	102	140	60
15	200	57	143	99	101	141	59
16	198	58	142	100	100	142	58
17	196	59	141	101	99	143	57
18	194	60	140	102	98	144	56
19	192	61	139	103	97	145	55
20	190	62	138	104	96	146	54
21	188	63	137	105	95	147	53
22	186	64	136	106	94	148	52
23	184	65	135	107	93	149	51
24	182	66	134	108	92	150	50
25	180	67	133	109	91	151	49
26	178	68	132	110	90	152	48
27	176	69	131	111	89	153	47
28	174	70	130	112	88	154	46
29	172	71	129	113	87	155	45
30	170	72	128	114	86	156	44
31	169	73	127	115	85	157	43
32	168	74	126	116	84	158	42
33	167	75	125	117	83	159	41
34	166	76	124	118	82	160	40
35	165	77	123	119	81	161	39
36	164	78	122	120	80	162	38
37	163	79	121	121	79	163	37
38	162	80	120	122	78	164	36
39	161	81	119	123	77	165	35
40	160	82	118	124	76	166	34
41	159	83	117	125	75	167	33

Ferrari Tribute to 1000 Miglia 2020
Regolamento Particolare di Gara – Special Race Regulations



FERRARI TRIBUTE TO 1000 MIGLIA 2020

POINTS TABLE FOR THE TIME TRIAL

centesimi di secondo		centesimi di secondo		centesimi di secondo		centesimi di secondo	
penalità	punti	penalità	punti	penalità	punti	penalità	punti
168	32	205	0	242	0	279	0
169	31	206	0	243	0	280	0
170	30	207	0	244	0	281	0
171	29	208	0	245	0	282	0
172	28	209	0	246	0	283	0
173	27	210	0	247	0	284	0
174	26	211	0	248	0	285	0
175	25	212	0	249	0	286	0
176	24	213	0	250	0	287	0
177	23	214	0	251	0	288	0
178	22	215	0	252	0	289	0
179	21	216	0	253	0	290	0
180	20	217	0	254	0	291	0
181	19	218	0	255	0	292	0
182	18	219	0	256	0	293	0
183	17	220	0	257	0	294	0
184	16	221	0	258	0	295	0
185	15	222	0	259	0	296	0
186	14	223	0	260	0	297	0
187	13	224	0	261	0	298	0
188	12	225	0	262	0	299	0
189	11	226	0	263	0	300	0
190	10	227	0	264	0		
191	9	228	0	265	0		
192	8	229	0	266	0		
193	7	230	0	267	0		
194	6	231	0	268	0		
195	5	232	0	269	0		
196	4	233	0	270	0		
197	3	234	0	271	0		
198	2	235	0	272	0		
199	1	236	0	273	0		
200	0	237	0	274	0		
201	0	238	0	275	0		
202	0	239	0	276	0		
203	0	240	0	277	0		
204	0	241	0	278	0		

Ferrari Tribute to 1000 Miglia 2020
Regolamento Particolare di Gara – Special Race Regulations



Allegato 8: Tabella dei punteggi per le Prove di Media - Points table for the Average Tests (PM/AT)

FERRARI TRIBUTE TO 1000 MIGLIA 2020
POINTS TABLE FOR THE AVERAGE TESTS

al secondo			al secondo			al secondo			al secondo		
penalità	punti ANTICIPO	punti RITARDO	penalità	punti ANTICIPO	punti RITARDO	penalità	punti ANTICIPO	punti RITARDO	penalità	punti ANTICIPO	punti RITARDO
0	420	420	42	53	158	84	0	116	126	-108	74
1	395	395	43	52	157	85	0	115	127	-111	73
2	370	370	44	51	156	86	0	114	128	-114	72
3	350	350	45	50	155	87	0	113	129	-117	71
4	330	330	46	48	154	88	0	112	130	-120	70
5	310	310	47	46	153	89	0	111	131	-123	69
6	291	291	48	44	152	90	0	110	132	-126	68
7	272	272	49	42	151	91	-3	109	133	-129	67
8	254	254	50	40	150	92	-6	108	134	-132	66
9	236	236	51	38	149	93	-9	107	135	-135	65
10	226	226	52	36	148	94	-12	106	136	-138	64
11	200	217	53	34	147	95	-15	105	137	-141	63
12	185	212	54	32	146	96	-18	104	138	-144	62
13	170	207	55	30	145	97	-21	103	139	-147	61
14	155	203	56	28	144	98	-24	102	140	-150	60
15	140	200	57	26	143	99	-27	101	141	-153	59
16	135	198	58	24	142	100	-30	100	142	-156	58
17	130	196	59	22	141	101	-33	99	143	-159	57
18	125	194	60	20	140	102	-36	98	144	-162	56
19	120	192	61	18	139	103	-39	97	145	-165	55
20	115	190	62	16	138	104	-42	96	146	-168	54
21	110	188	63	14	137	105	-45	95	147	-171	53
22	105	186	64	12	136	106	-48	94	148	-174	52
23	100	184	65	10	135	107	-51	93	149	-177	51
24	95	182	66	8	134	108	-54	92	150	-180	50
25	90	180	67	6	133	109	-57	91	151	-183	49
26	85	178	68	4	132	110	-60	90	152	-186	48
27	80	176	69	2	131	111	-63	89	153	-189	47
28	75	174	70	0	130	112	-66	88	154	-192	46
29	70	172	71	0	129	113	-69	87	155	-195	45
30	65	170	72	0	128	114	-72	86	156	-198	44
31	64	169	73	0	127	115	-75	85	157	-201	43
32	63	168	74	0	126	116	-78	84	158	-204	42
33	62	167	75	0	125	117	-81	83	159	-207	41
34	61	166	76	0	124	118	-84	82	160	-210	40
35	60	165	77	0	123	119	-87	81	161	-213	39
36	59	164	78	0	122	120	-90	80	162	-216	38
37	58	163	79	0	121	121	-93	79	163	-219	37
38	57	162	80	0	120	122	-96	78	164	-222	36
39	56	161	81	0	119	123	-99	77	165	-225	35
40	55	160	82	0	118	124	-102	76	166	-228	34
41	54	159	83	0	117	125	-105	75	167	-231	33

Ferrari Tribute to 1000 Miglia 2020
Regolamento Particolare di Gara – Special Race Regulations



FERRARI TRIBUTE TO 1000 MIGLIA 2020
POINTS TABLE FOR THE AVERAGE TESTS

al secondo			al secondo			al secondo			al secondo		
penalità	punti ANTICIPO	punti RITARDO	penalità	punti ANTICIPO	punti RITARDO	penalità	punti ANTICIPO	punti RITARDO	penalità	punti ANTICIPO	punti RITARDO
168	-234	32	205	-345	0	242	-456	0	279	-567	0
169	-237	31	206	-348	0	243	-459	0	280	-570	0
170	-240	30	207	-351	0	244	-462	0	281	-573	0
171	-243	29	208	-354	0	245	-465	0	282	-576	0
172	-246	28	209	-357	0	246	-468	0	283	-579	0
173	-249	27	210	-360	0	247	-471	0	284	-582	0
174	-252	26	211	-363	0	248	-474	0	285	-585	0
175	-255	25	212	-366	0	249	-477	0	286	-588	0
176	-258	24	213	-369	0	250	-480	0	287	-591	0
177	-261	23	214	-372	0	251	-483	0	288	-594	0
178	-264	22	215	-375	0	252	-486	0	289	-597	0
179	-267	21	216	-378	0	253	-489	0	290	-600	0
180	-270	20	217	-381	0	254	-492	0	291	-603	0
181	-273	19	218	-384	0	255	-495	0	292	-606	0
182	-276	18	219	-387	0	256	-498	0	293	-609	0
183	-279	17	220	-390	0	257	-501	0	294	-612	0
184	-282	16	221	-393	0	258	-504	0	295	-615	0
185	-285	15	222	-396	0	259	-507	0	296	-618	0
186	-288	14	223	-399	0	260	-510	0	297	-621	0
187	-291	13	224	-402	0	261	-513	0	298	-624	0
188	-294	12	225	-405	0	262	-516	0	299	-627	0
189	-297	11	226	-408	0	263	-519	0	300	-630	0
190	-300	10	227	-411	0	264	-522	0	>300	-12000	0
191	-303	9	228	-414	0	265	-525	0			
192	-306	8	229	-417	0	266	-528	0			
193	-309	7	230	-420	0	267	-531	0			
194	-312	6	231	-423	0	268	-534	0			
195	-315	5	232	-426	0	269	-537	0			
196	-318	4	233	-429	0	270	-540	0			
197	-321	3	234	-432	0	271	-543	0			
198	-324	2	235	-435	0	272	-546	0			
199	-327	1	236	-438	0	273	-549	0			
200	-330	0	237	-441	0	274	-552	0			
201	-333	0	238	-444	0	275	-555	0			
202	-336	0	239	-447	0	276	-558	0			
203	-339	0	240	-450	0	277	-561	0			
204	-342	0	241	-453	0	278	-564	0			